

I. Picture



II. Introduction

The control driver is suitable for driving type 57 stepper motors, mounted to the rear of stepper motors and powered by 12~36V DC.

The control driver includes three models: JBT-BM, JBT-BT, QBT-M1.

III. Dimension

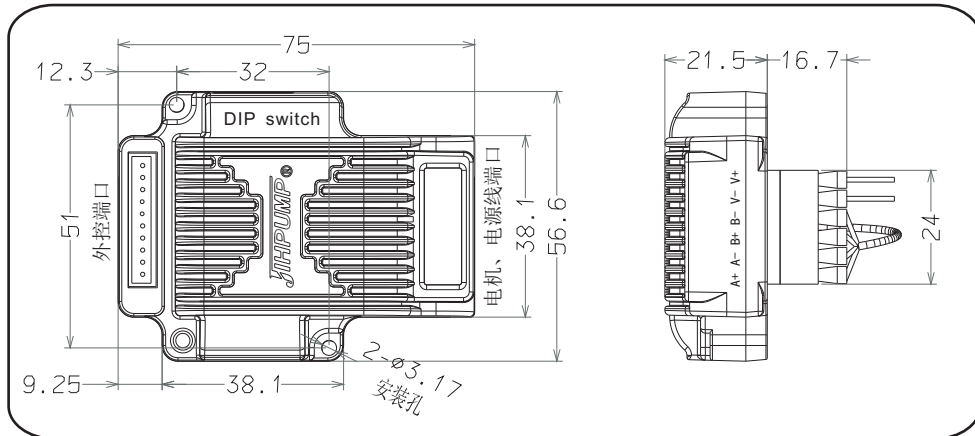

Please use this controller in a dry, ventilated, temperature-friendly environment, and do not use it in a humid and high temperature environment!

IV. Specification (outside of the housing is marked with model no.)

1. Model JBT-BM



JBT-BM voltage type controller is powered by 12V ~ 36V DC power supply.

The driving current and the maximum speed can be set by the DIP switch. The speed of the motor can be adjusted by the built-in potentiometer, external voltage and external current. The speed includes internal and external speed. And the motor can be controlled to start/stop and forward/reverse through the external control port.

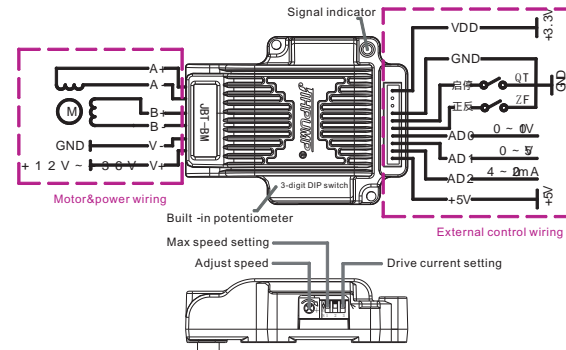

Remark :

1. In the DIP switch definition table, 1 # and 2 # set the maximum speed, and 3 # selects the drive current;
2. The built-in potentiometer adjusts the speed, rotate clockwise, the speed increases; rotate counterclockwise, the speed decreases; **the factory has adjusted the potentiometer to the maximum speed;**
3. In the wiring diagram of the external control port, AD0 / AD1 / AD2 and the built-in potentiometer are speed adjustment signals. Only one signal can be selected when used, and other signals must be 0 (**If the governor speed is not returned to 0, the speed will be added**).
4. In the wiring diagram of the external control port, the QT switch signal controls the motor to start/stop, short-circuit to start, disconnect to stop; QT can also input the PWM duty pulse to control the motor speed according to the proportion and the return difference. The duty ratio 0% for the highest speed, and on the contrary for the lowest speed; above 95% duty ratio to stop, below 90% duty ratio to start;
5. ZF switch signal controls the direction of the motor, short-circuit for counterclockwise rotation, disconnect for clockwise rotation;
6. The signal indicator on the circuit board, when the motor is working, it lights up, and the motor is off when it is not working; in addition, the infrared speed can be used to detect the speed of the motor through the signal indicator;
7. **Drive current setting: motor rated current ≤ 2.4A, select 3A; motor rated current > 2.4A, select 5A.**

DIP Switch Definition				
1#	2#	Speed	3#	Drive current
OFF	OFF	0~600rpm	ON	3A
OFF	ON	0~300rpm		
ON	OFF	0~150rpm	OFF	5A
ON	ON	0~60rpm		

2. Model JBT-BT



The current of JBT-BT communication controller is powered by 12V ~ 36V DC power supply.

The drive current, communication address and communication parameters of the motor can be set through the DIP switch. The start/stop, forward/reverse rotation and speed of the motor are controlled by the MODBUS protocol.

Remark :

- In the DIP switch definition table, 1 #, 2 #, 3 #, 4 # set the communication address, 5 # select the communication parameter, 6 # select the drive current;
- In the wiring diagram of the external control port, the signal of the QY liquid shortage switch is closed for normal control, and disconnect for shutdown protection;
- The signal indicator on the circuit board lights up when the motor is working; if the motor does not work and there is a communication signal, the indicator flashes; if the motor does not work and there is no communication signal, the indicator goes off; it can also be used through the signal indicator infrared speedometer detects motor speed;
- Drive current setting: motor rated current $\leq 2.4A$, select 3A; motor rated current $> 2.4A$, select 5A.**

MODBUS RTU parameters:

- The command codes implemented are 1, 2, 3, 4, 5, 6, 15 and 16, the following addresses are all protocol addresses;
- Input relay, bit address 0 is QY (liquid shortage);
- Output relay, bit address 0 is QT (start and stop), bit address 1 is ZF (positive and negative);
- The input register is undefined;
- Output register, word address 0 is SPEED (speed), 0 ~ 6000 \rightarrow 0 ~ 600.0RPM.

DIP Switch Definition								
1#	2#	3#	4#	Address	5#	Parameter	6#	Drive current
OFF	OFF	OFF	OFF	16	ON	9600 E 8 1	ON	3A
OFF	OFF	OFF	ON	15				
OFF	OFF	ON	OFF	14				
OFF	OFF	ON	ON	13				
OFF	ON	OFF	OFF	12				
OFF	ON	OFF	ON	11				
OFF	ON	ON	OFF	10				
OFF	ON	ON	ON	9				
ON	OFF	OFF	OFF	8				
ON	OFF	OFF	ON	7				
ON	OFF	ON	OFF	6	OFF	115200 N 8 1	OFF	5A
ON	OFF	ON	ON	5				
ON	ON	OFF	OFF	4				
ON	ON	OFF	ON	3				
ON	ON	ON	OFF	2				
ON	ON	ON	ON	1				

3. Model QBT-M1



The QBT-M1 controller is powered by a 12V to 36V DC power supply.

The input subdivision number, VCC voltage and drive current can be set by the DIP switch. The external control accept the pulse, direction and enable signals to control the start/ stop, forward/reverse and the speed of the motor.

Remark :

- In the dial switch definition table, 1#, 2# set the input subdivision number, 3#, 4# select the drive current, 6# select the VCC interface voltage, and 5# dial switch has no definition;
- In the external control terminal wiring diagram, the higher the pulse frequency, the faster the rotation speed; CW is high for clockwise rotation, low for counterclockwise rotation; EN is low for stop, high for operation;
- The signal indicator on the circuit board, when the motor is working, it will be illuminated, and when the motor is not working, it will be extinguished; the signal indicator can also be used to detect the motor speed by using the infrared speedometer;
- Drive current setting description: motor rated current $\leq 2.4A$, select 3A; motor rated current $> 2.4A$, select 5A. The user can select the drive current according to the actual load, select a small drive current for a small load, and select a large drive current for a larger load.

DIP Switch Definition								
1#	2#	Input subdivision number	3#	4#	Driver current	6#	VCC voltage	5#
OFF	OFF	32	OFF	OFF	2A	ON	5V	no definition
OFF	ON	16	OFF	ON	3A			
ON	OFF	8	ON	OFF	4A	OFF	24V	
ON	ON	4	ON	ON	5A			